

CHM-12
[175 WATT MAX.]

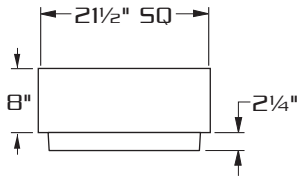

CHM-20
[400 WATT MAX.]

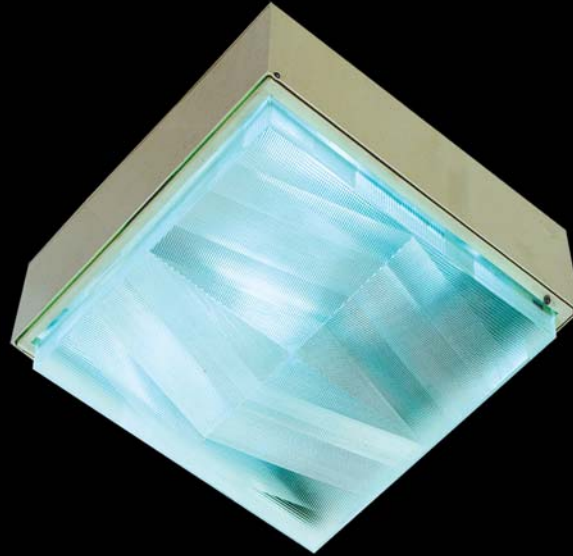

SPECIFICATIONS:

- HOUSING:** ONE PIECE, DIE FORMED ALUMINUM CONSTRUCTION. ALUMINUM DOOR FRAME PROVIDED WITH SPRING LOADED HINGE AND A SPRING LOADED FASTENER FOR EASY ACCESS.
- OPTICS:** SEMI-SPECULAR ALUMINUM REFLECTOR COMBINES WITH INJECTION MOLDED, PRISMATIC ACRYLIC LENS TO PROVIDE SHIELDED WIDE ANGLE LIGHT DISTRIBUTION.
- GASKETING:** CLOSED CELL EPDM GASKETING COMPRESSED BETWEEN DOOR AND HOUSING SEALS OPTICAL CHAMBER.
- LAMP HOLDER:** MOGUL BASE PORCELAIN WITH LAMP LOCKING SHELL.
- LAMP:** [BY OTHERS]
- BALLAST:** H.P.F./C.W.A. AUTOTRANSFORMER. -20° STARTING TEMPERATURE.
- OPTION:** **CNP** - CAST ALUMINUM CANOPY 1"X8"X10"
SC - HEAVY WALL ALUMINUM SURFACE COLLAR 2 1/2"X8"X10" FOR SURFACE CONDUIT. FOUR 7/8" K.O.'S PROVIDED.
- FINISH:** POLYESTER POWDER COAT-STATE OF THE ART 20 PSI PRESSURE POWER WASH AT 140° TEMPERATURE INCORPORATES FOUR STEP IRON PHOSPHATE PROCESS TO CLEANSE AND PRETREAT THE METAL SURFACE FOR MAXIMUM PAINT ADHESION. ELECTROSTATICALLY APPLIED TEXTURED POLYESTER POWDER TOPCOAT IS BAKED AT 400° TEMPERATURE FOR MAXIMUM HARDNESS AND EXTERIOR DURABILITY.



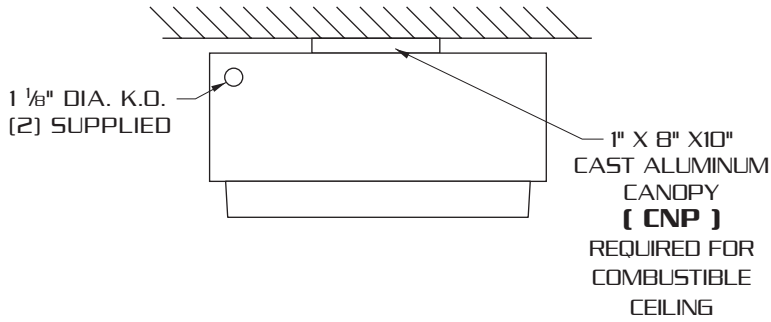

BACK SIDE

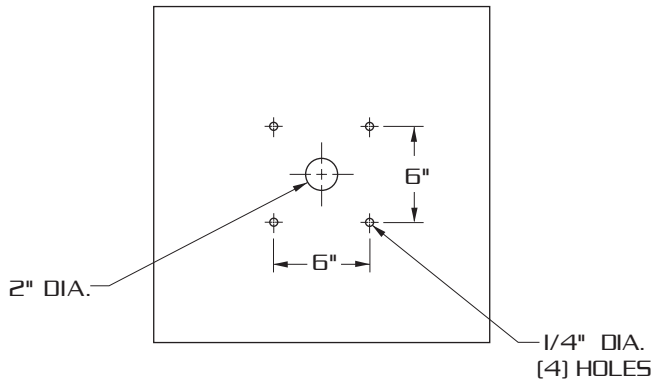

**LAMP SIZE:
70 - 400 WATT**

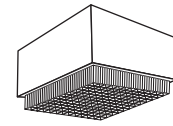

CHM-12
[175 W. MAX.]

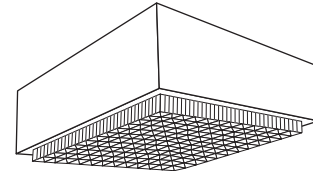

CHM-20
[400 W. MAX.]

**INJECTION MOLDED PRISMATIC
REFRACTOR.**

**HINGED GASKETED DOOR
FRAME.**

ORDERING INFORMATION

MODEL NO. : CHM	OPTICS	WATTAGE TYPE VOLTAGE	FINISH	OPTIONS
MODEL NO. : CHM	OPTICS	LAMP	FINISH	OPTIONS
C H M	<input type="checkbox"/> CLEAR PRISMATIC ACRYLIC CA	WATTAGE TYPE VOLTAGE	<input type="checkbox"/> DARK BRONZE DBM	<input type="checkbox"/> #73 CRYSTAL TEMPERED GLASS. TPG
	<input type="checkbox"/> CLEAR PRISMATIC POLYCARBONATE CP	<input type="checkbox"/> 400 <input type="checkbox"/> HPS <input type="checkbox"/> 120	<input type="checkbox"/> MEDIUM BRONZE MBM	<input type="checkbox"/> OPAL ACRYLIC DISH LENS. OD
		<input type="checkbox"/> 250 <input type="checkbox"/> MH <input type="checkbox"/> 208	<input type="checkbox"/> BLACK BKM	<input type="checkbox"/> SINGLE FUSE (120V., 277V). SF
		<input type="checkbox"/> 200 <input type="checkbox"/> MV <input type="checkbox"/> 240	<input type="checkbox"/> WHITE WTM	<input type="checkbox"/> DOUBLE FUSE (208V., 240V). DF
		<input type="checkbox"/> 175 <input type="checkbox"/> 277	<input type="checkbox"/> SILVER SLM	<input type="checkbox"/> QUARTZ RESTRIKE. QTZ
		<input type="checkbox"/> 150 <input type="checkbox"/> 480		<input type="checkbox"/> SURFACE COLLAR 2 1/2"X8"X10". SC
		<input type="checkbox"/> 100 <input type="checkbox"/> MT		<input type="checkbox"/> CANOPY. CNP
		<input type="checkbox"/> 75		
		<input type="checkbox"/> 70		
				SEE PAGE 3 FOR ADDITIONAL COLORS



660 WEST AVENUE O, PALMDALE, CA. 93551
(661) 233-2000
FAX NO. (661) 233-2001
www.usaltg.com